



MHV Male Connector Clamp/Solder Attachment For RG58, RG55, RG141, RG142, RG223, RG400

TECHNICAL DATA SHEET

PE4076

MHV Male Connector Clamp/Solder Attachment For RG58, RG55, RG141, RG142, RG223, RG400

Configuration

Connector	MHV Male
Connector Specification	MIL-STD-348A
Connector Interface Type	RG58, RG55, RG141, RG142, RG223, RG400
Cable Attachment Method (Shield/Contact)	Clamp/Solder
Body Style	Straight

Electrical Specifications

Frequency Range, MHz	DC to 300
Impedance, Ohms	50
Maximum VSWR	1.3:1
Maximum Operating Voltage, Volts	1,600
Dielectric Withstanding Voltage, Vrms	5,000

Mechanical Specifications

Temperature

Operating Range, deg C	-65 to +165
------------------------	-------------

Size

Length, in [mm]	1.52 [38.61]
Width/Dia., in [mm]	0.57 [14]
Weight, lbs [g]	0.055 [24.95]

Connector

Type	MHV Male
Contact Material and Plating	Brass, Gold
Contact Plating Specification	30µ in. minimum
Coupling Nut Material and Plating	Brass, Nickel
Coupling Nut Plating Specification	100µ in. minimum
Body Material and Plating	Brass, Nickel
Body Plating Specification	100µ in. minimum
Dielectric Type	Teflon

Compliance Certifications (visit www.Pasternack.com for current document)

RoHS Compliant	Yes
----------------	-----

Plotted and Other Data

Notes: Values at 25 °C, sea level

URL: <http://www.pasternack.com/mhv-male-standard-rg58-rg55-rg141-rg142-rg223-rg400-connector-pe4076-p.aspx>

MHV Male Connector Clamp/Solder Attachment For RG58, RG55, RG141, RG142, RG223, RG400 from Pasternack Enterprises has same day shipment for domestic and International orders. We maintain 99% availability of the industry's broadest selection of RF, microwave and fiber optic products.

The information contained in this document is accurate to the best of our knowledge and representative of the part described herein. It may be necessary to make modifications to the part and/or the documentation of the part, in order to implement improvements. Pasternack reserves the right to make such changes as required. Unless otherwise stated, all specifications are nominal.

PE4076 CAD Drawing

MHV Male Connector Clamp/Solder Attachment For RG58, RG55, RG141, RG142, RG223, RG400

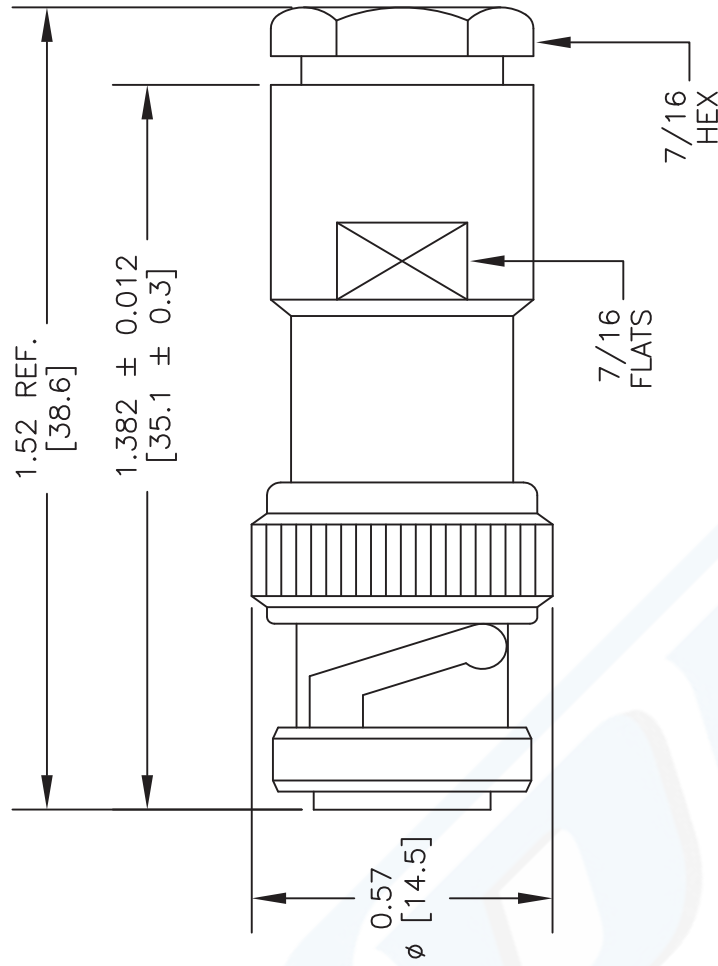

ASSEMBLY PROCEDURES

1. SLIDE CLAMP NUT (1), WASHER (2) & GASKET (3) OVER CABLE AS SHOWN.
2. TRIM PER DIMENSIONS.
3. a) SLIDE BRAID CLAMP OVER BRAID UNTIL IT STOPS ON CABLE JACKET.
 b) FLAIR BRAID AS SHOWN.
4. INSTALL CONTACT BY SOLDERING TO CABLE CENTER CONDUCTOR LEAVING NO GAPS (5).
5. REMOVE EXCESS SOLDER. INSERT ASSEMBLY INTO CONNECTOR BODY AND TIGHTEN NUT.

DWG TITLE

PE4076

NOTES:
 1. UNLESS OTHERWISE SPECIFIED ALL DIMENSIONS ARE NOMINAL.
 2. ALL SPECIFICATIONS ARE SUBJECT TO CHANGE WITHOUT NOTICE AT ANY TIME.
 3. DIMENSIONS ARE IN INCHES [mm].
 4. FITS MIL-C-17 AND EQUIVALENT CABLES.

PE PASTERNAK®
 Pasternack Enterprises, Inc.
 P.O. Box 16759 | Irvine | CA | 92623
 Phone: (949) 261-1920 | Fax: (949) 261-7451
 Website: www.pasternack.com | E-Mail: sales@pasternack.com

CAD REV. A FSCM NO. 53919 CAD FILE 090412 SCALE N/A SIZE A 2233